

THROWBACK BIKES

ZX Rear Moto Fender

Installation Guide

Version 1.0

THANKS FOR PURCHASING THIS FENDER! PLEASE READ ALL INSTRUCTIONS BEFORE INSTALLING. IF YOU HAVE TROUBLE DON'T HESITATE TO CONTACT US AT info@throwbackbikes.com

PARTS

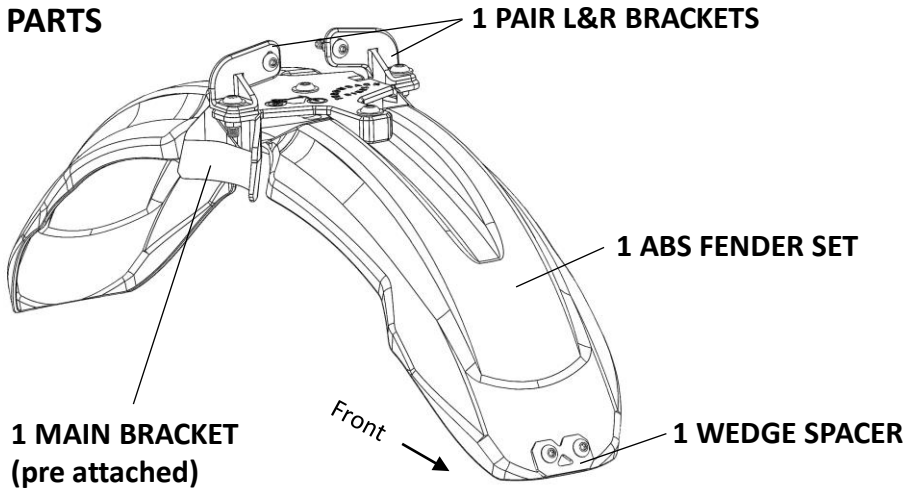

HARDWARE

4 SETS M4 BOLTS, NUTS, WASHERS (Smaller ones)

2 SETS M6 BOLTS, NUTS, WASHERS (Larger ones)

TOOLS REQUIRED

4MM HEX KEY (ALLEN)

PHILLIPS SCREW DRIVER

10MM WRENCH OR SOCKET

7MM WRENCH OR SOCKET

STEP 1. Attach Left and Right Brackets to the Main Bracket as shown with the M6 bolts from above and the washers and nuts underneath. Do not tighten completely. Guide the fender into the frame above the rear wheel, making sure the front lower part of the fender is to the **REAR** of the lower bracket on the frame of the bike. Slip an M4 bolt through each of the left and right brackets and through the lower slots in the plate on the frame of the bike. Start an M4 nut on the back side of each bolt. Do not tighten completely yet.

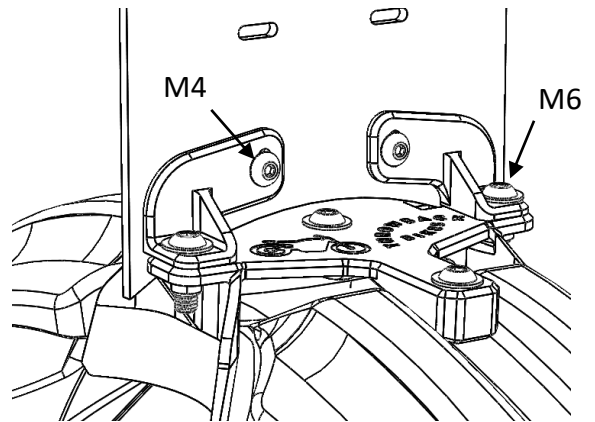

STEP 2. Orient the Wedge Spacer as shown above, in-between the fender and the bracket on the bike with the slots. Slip 2 M4 bolts from the front, through the bike bracket, the wedge spacer, and the drilled holes on the fender. Start 2 M4 nuts onto the bolts inside the fender.

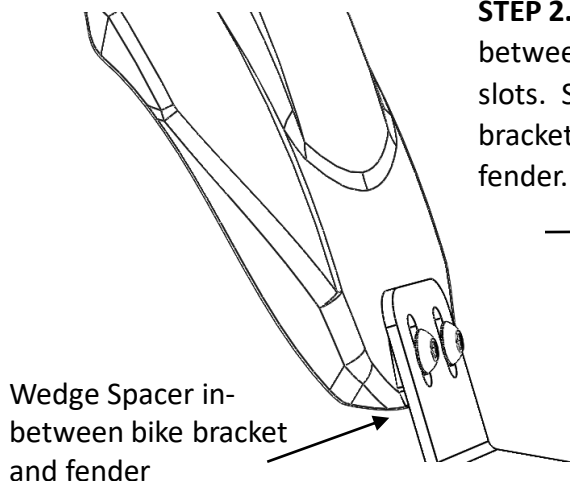

STEP 3. Double check that the fender is aligned properly and then tighten all the bolts and nuts until they are snug. Don't overtighten bolts!

That's it! We hope you love your new fender.