

# THROWBACK BIKES

## S2 Rear Moto Fender Installation Guide

Version 1.0

THANKS FOR PURCHASING THIS FENDER! PLEASE READ ALL INSTRUCTIONS BEFORE INSTALLING. IF YOU HAVE TROUBLE DON'T HESITATE TO CONTACT US AT [info@throwbackbikes.com](mailto:info@throwbackbikes.com)

### PARTS

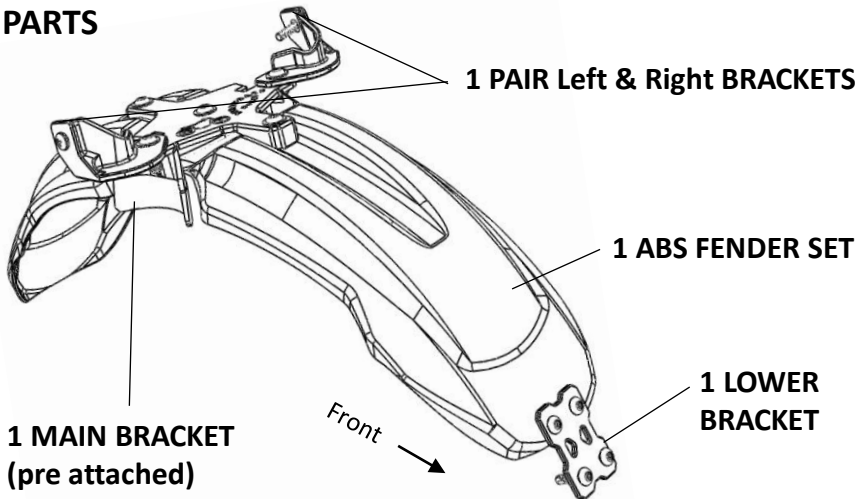

### HARDWARE

4 SETS M4 BOLTS, NUTS, WASHERS (Smaller ones)

2 SETS M5 BOLTS, WASHERS (Medium ones)

2 SETS M6 BOLTS, NUTS, WASHERS (Larger ones)

### TOOLS REQUIRED

3mm and 4mm HEX KEYS (ALLEN)  
10mm WRENCH OR SOCKET  
7mm WRENCH OR SOCKET  
PHILLIPS SCREWDRIVER

**STEP 1.** Attach Left and Right Brackets to the Main Bracket as shown with the M6 bolts from above and the washers and nuts underneath. **Do not** tighten completely. Now attach the Lower Bracket securely to the predrilled holes in the front of the fender with the M4 hardware as shown above. Next, gently guide the fender into the frame above the rear wheel. Take care to guide any cables into the groove on the left side bracket while aligning the brackets with the threaded holes in the bike frame. Attach the Left and Right Brackets **loosely** with M5 bolts and washers.

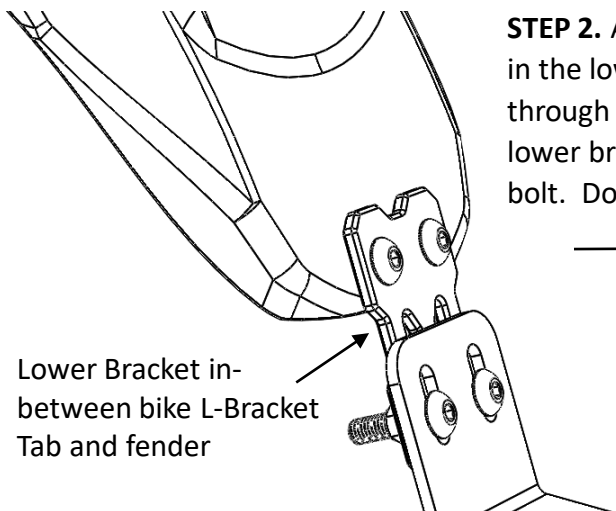
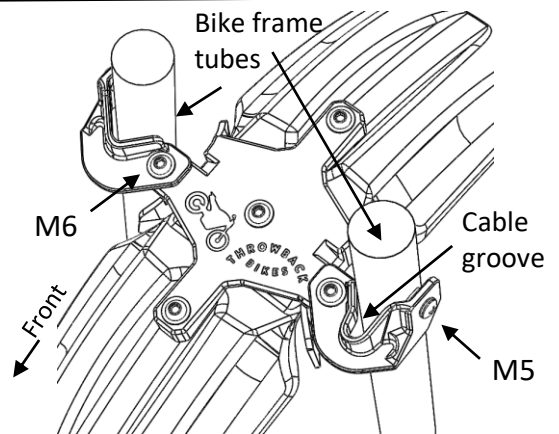

**STEP 2.** Align the Lower Bracket **BEHIND** the L-Bracket Tab in the lower part of the bike frame. Slip an M4 bolt through each of the left and right slots and through the lower bracket. Start an M4 nut on the back side of each bolt. Do not tighten completely yet.

**STEP 3.** Double check that the fender is aligned properly (have a friend temporarily hold it in place, or use some padding between the tire and fender, or use some tape to hold it if necessary). Once aligned, tighten all the bolts and nuts until they are snug. Don't overtighten bolts!

**That's it! We hope you love your new fender.**