

THROWBACK BIKES

RR MIDFRAME MOLLE PANEL

Installation Guide

Version 1.0

THANKS FOR PURCHASING THIS MIDFRAME MOLLE PANEL!
PLEASE READ ALL INSTRUCTIONS BEFORE INSTALLING. IF YOU
HAVE TROUBLE DON'T HESITATE TO CONTACT US AT
info@throwbackbikes.com

PARTS

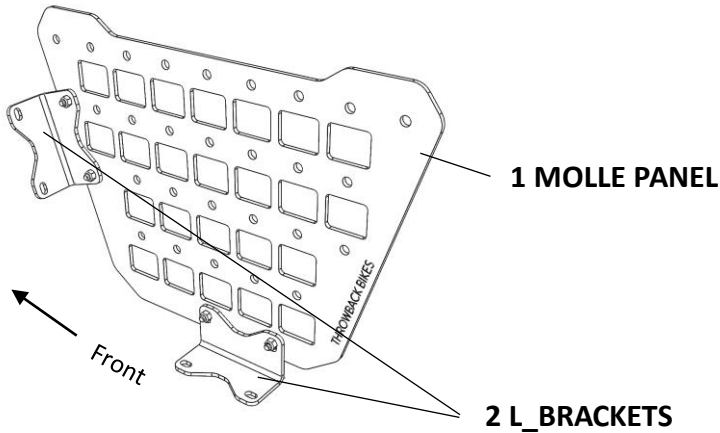

HARDWARE

- 8 M5 BOLTS
- 4 M5 LOCKING NUTS
- 12 M5 WASHERS
- 4 M5 LOCK WASHERS

TOOLS REQUIRED

- PHILLIPS SCREW DRIVER
- 8MM WRENCH OR SOCKET

STEP 1. Align both L Brackets with the slots in the MOLLE Panel as shown to the right. Using 2 M5 Bolts with a flat washers per bracket insert the bolts through from the MOLLE Panel side. Secure with a flat washer and a nut on the L Bracket side. Do tighten fully at this point.

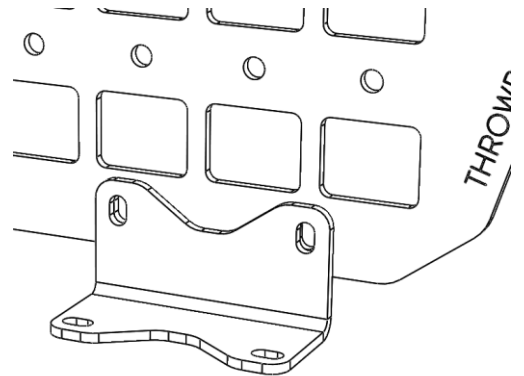

STEP 2. Place the assembly onto your Rad Runner bike and align with the threaded holes on the frame. Using a total of 4 M5 bolts with a lock washer and a flat washer on each bolt, thread the bolts through the L-Brackets and into the threaded holes on the frame. Start all the bolts before tightening any of them. Once all the bolts are started, tighten securely. Next, adjust the position of the MOLLE Panel and tighten the hardware from Step 1.

That's it! We hope you love your new fender.